

| NOZZLE CHART | | |
|--------------|----------|-------------|
| NOZZLE ID | NPS SIZE | TYPE |
| N1 | 2 | NPT |
| N2 | 8 | 150# FLG |
| N3 | 3/4 | NPT |
| N4 | 1 | NPT |
| N5 | 12 X16 | MANWAY 300# |

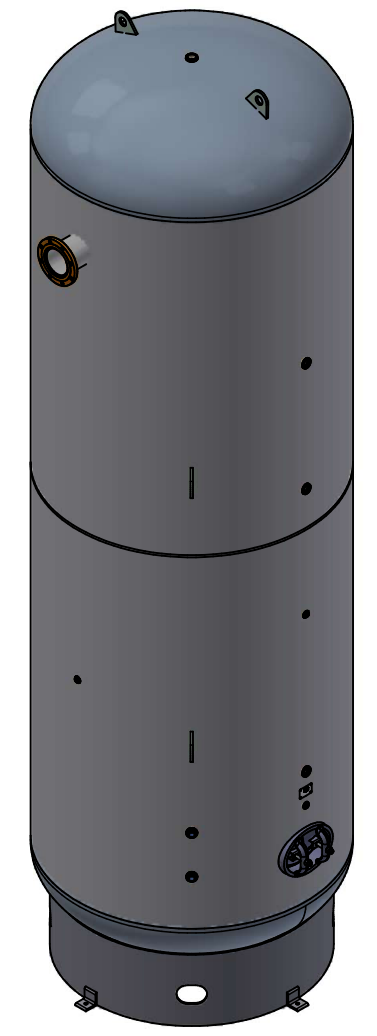
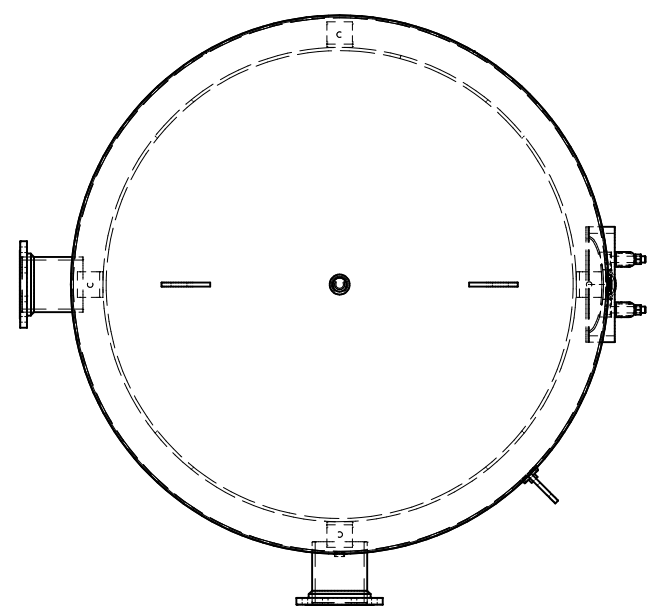

| DESIGN INFORMATION | |
|--------------------|---------------------|
| SPECIFICATION | VALUE |
| DIAMETER O.D./I.D. | 84 O.D. |
| MAWP | 150 PSI AT 450°F |
| MDMT | -20°F AT 150 PSI |
| CAPACITY | APPROX 6000 GALLONS |
| SHIPPING WEIGHT | 9000 LBS |
| CRN | H9097.5C |

(BUILT IN ACCORDANCE WITH LATEST EDITION OF SECTION VIII DIV 1 ASME CODE)

THIS DRAWING & SPECIFICATIONS ARE PROPERTY OF SILVAN IND. INC. AND MAY NOT BE COPIED, REPRODUCED, OR USED IN WHOLE OR PART, AS A BASIS FOR DESIGN MANUFACTURE OR SALE WITHOUT PRIOR PERMISSION FROM SILVAN IND. INC.

| | | | | | |
|--|---------------------------------------|--|---------------------|-----------------|--|
| UNLESS OTHERWISE SPECIFIED INCH TOLERANCES .X.....±.1 .XX.....±.02 .XXX.....±.005 FRACTIONS.....±1/16 ANGLE.....±1° FINISH.....250 THIRD ANGLE PROJ | TITLE VERTICAL AIR RECEIVER | | | | |
| | CUSTOMER CATALOG | | | | DRAWN MG 2/6/2025 |
| | CUST INFO DWG NO. NONE PART NO. | | TYPE ASME | | DRAWING NO 127298 LEGACY PART NO 132-272SF |
| | | | SIZE: B | REV 7 | SHEET 1 OF 1 |