

NOZZLE CHART		
NOZZLE ID	NPS SIZE	TYPE
N1	1	NPT
N2	1.5	NPT
N3	2	NPT
N4	10	150# FLG
N5	12 X16	MANWAY 300#

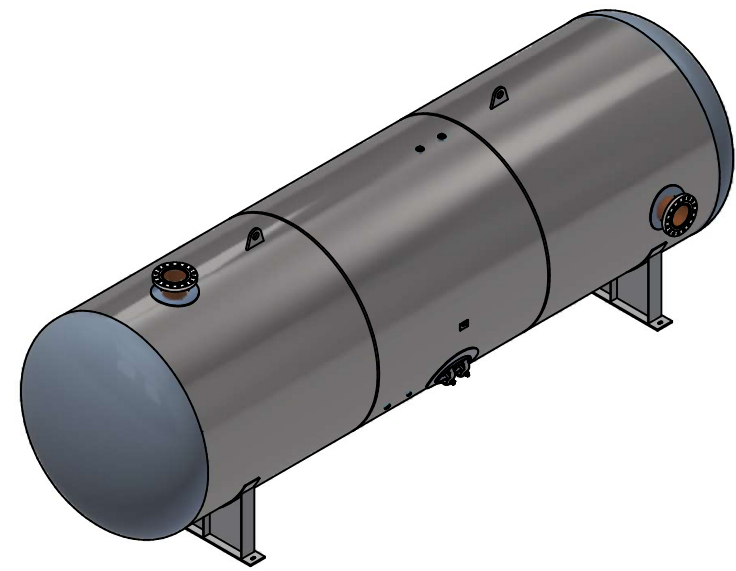
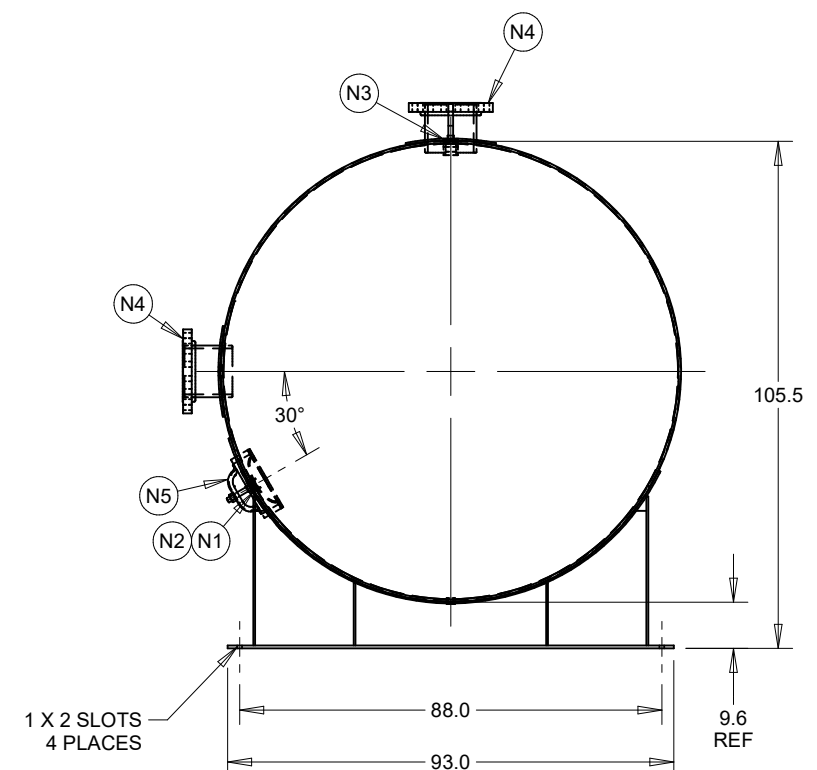
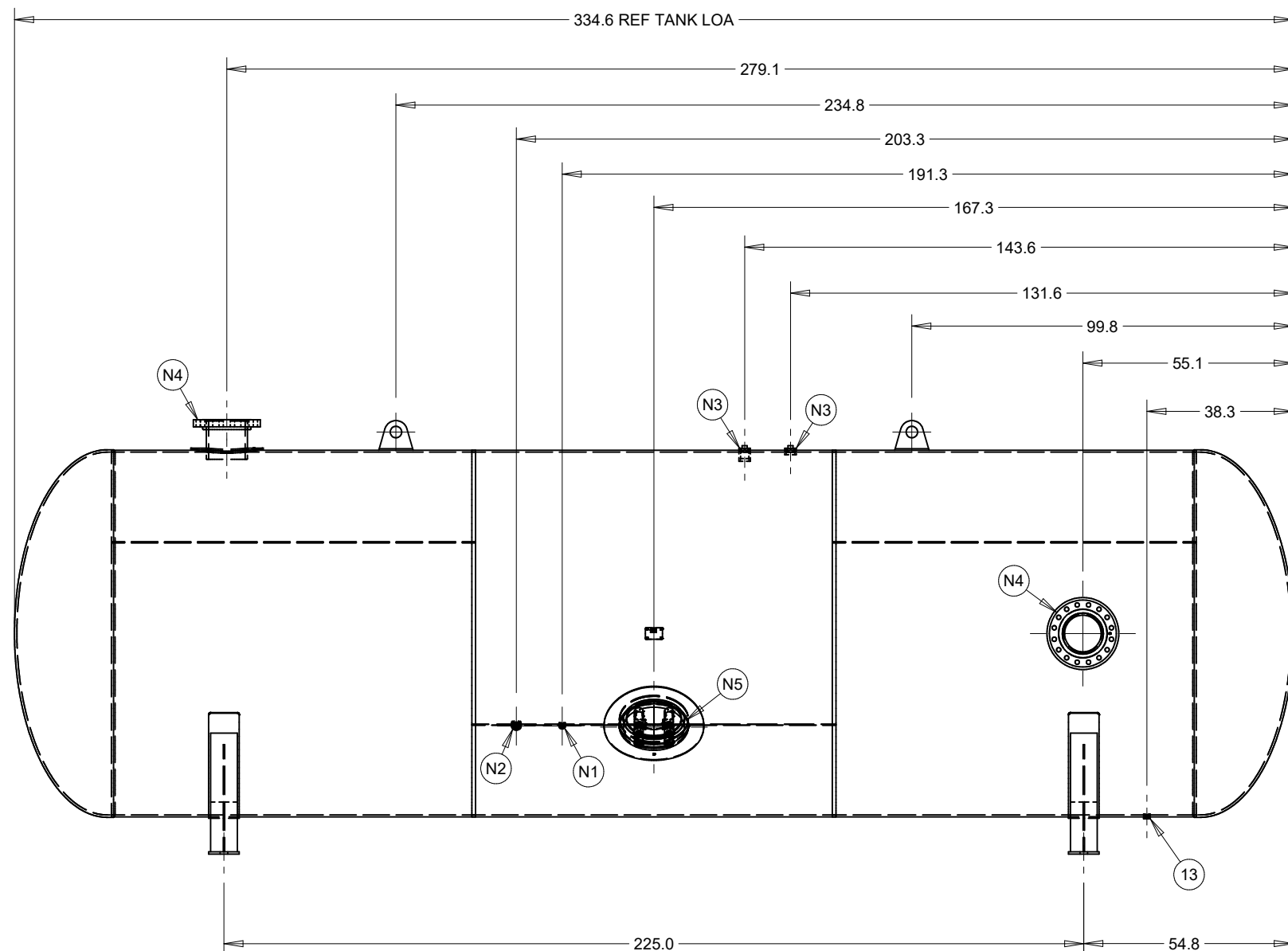

DESIGN INFORMATION	
SPECIFICATION	VALUE
DIAMETER O.D./I.D.	96 O.D.
MAWP	200 PSI AT 400°F
MDMT	-20°F AT 200 PSI
CAPACITY	APPROX 10,000 GALLONS
SHIPPING WEIGHT	18,000 LBS
CRN	NONE

(BUILT IN ACCORDANCE WITH LATEST EDITION OF SECTION VIII DIV 1 ASME CODE)

THIS DRAWING & SPECIFICATIONS ARE PROPERTY OF SILVAN IND. INC. AND MAY NOT BE COPIED, REPRODUCED, OR USED IN WHOLE OR PART, AS A BASIS FOR DESIGN MANUFACTURE OR SALE WITHOUT PRIOR PERMISSION FROM SILVAN IND. INC.

REV	DESCRIPTION	BY	DATE
1	ISSUED		

UNLESS OTHERWISE SPECIFIED INCH TOLERANCES  
 .X.....±.1  
 .XX.....±.02  
 .XXX.....±.005  
 FRACTIONS.....±1/16  
 ANGLE.....±1°  
 FINISH.....250

THIRD ANGLE PROJ

TITLE  
**HORIZONTAL AIR RECEIVER**

CUSTOMER  
**CATALOG**

TYPE  
 ASME

**SAMUEL** 1865  
 PRESSURE VESSEL GROUP

DRAWN AET 1/29/2025	CHECKED BW 1/27/2025	DRAWING NO <b>237311</b> LEGACY PART NO 131-974	REV <b>1</b>
---------------------------	----------------------------	----------------------------------------------------------	-----------------

SIZE: B SHEET 1 OF 1