

NOZZLE CHART		
NOZZLE ID	NPS SIZE	TYPE
N1	1	NPT
N2	2	NPT
N3	2.5	NPT
N4	3	NPT
N5	10	150# FLG
N6	12 X16	MANWAY 300#

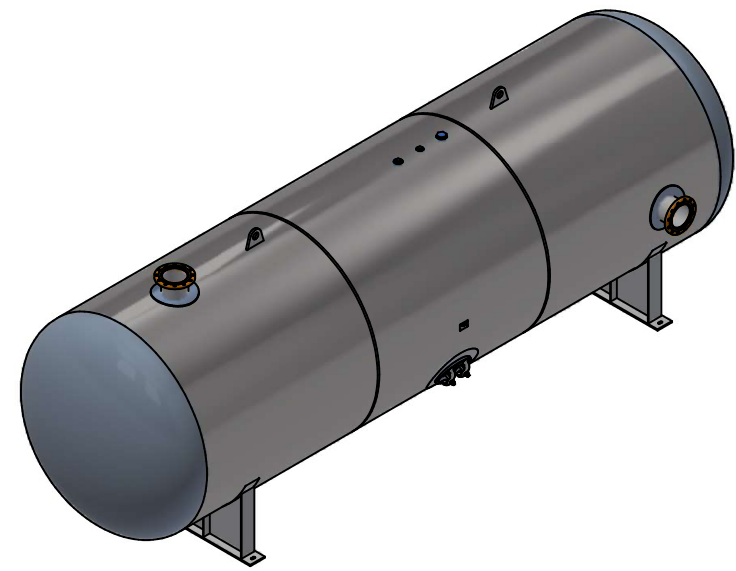
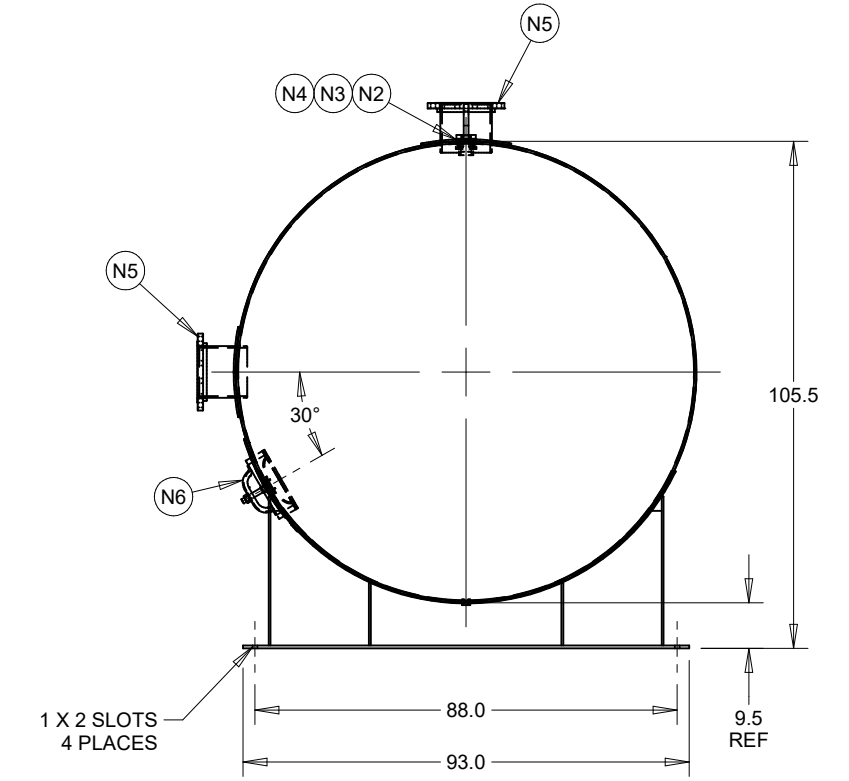
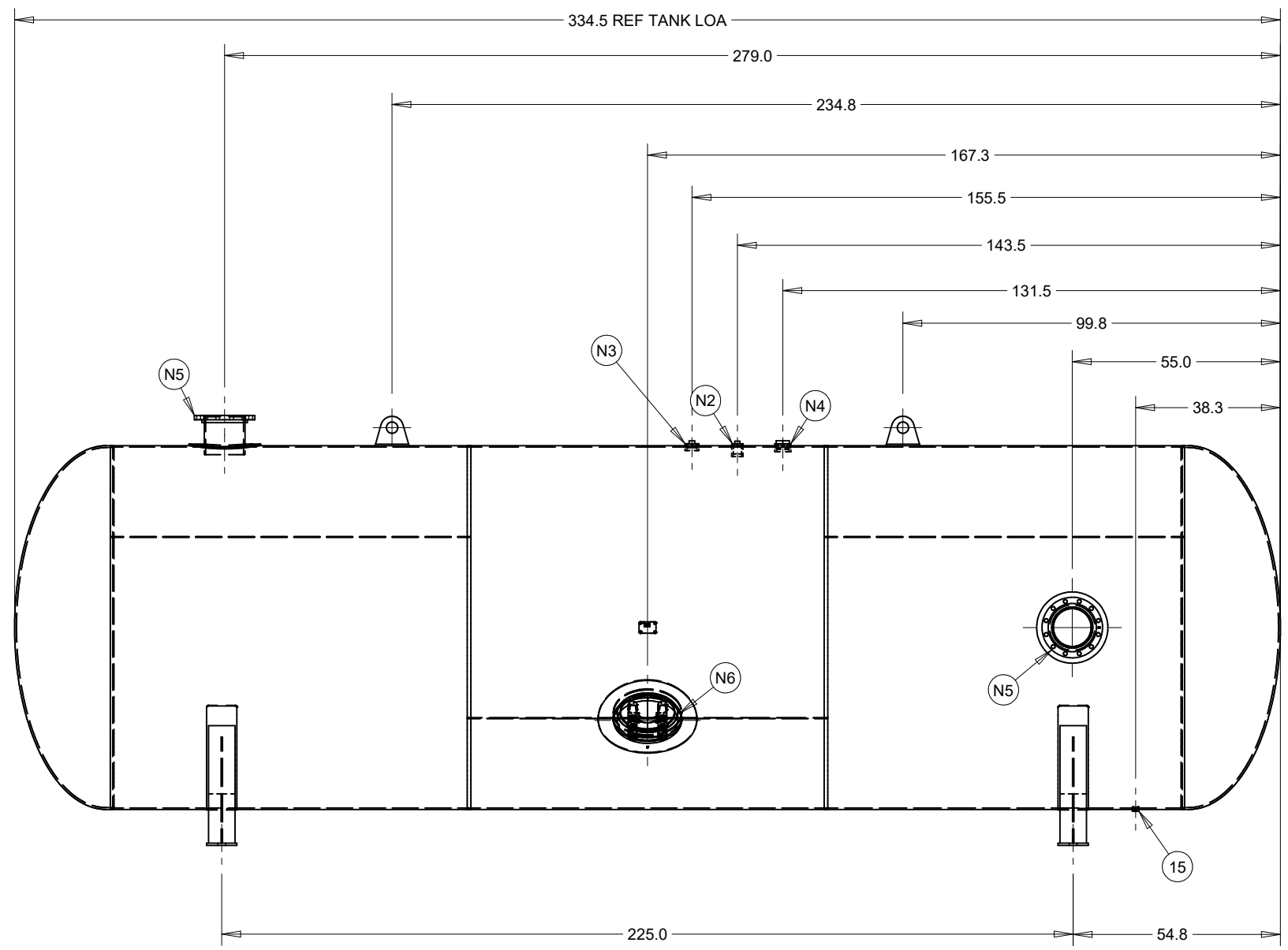

DESIGN INFORMATION	
SPECIFICATION	VALUE
DIAMETER O.D./I.D.	96 O.D.
MAWP	150 PSI AT 450°F
MDMT	-20°F AT 150 PSI
CAPACITY	APPROX 10,000 GALLONS
SHIPPING WEIGHT	14,000 LBS
CRN	NONE

(BUILT IN ACCORDANCE WITH LATEST EDITION OF SECTION VIII DIV 1 ASME CODE)

THIS DRAWING & SPECIFICATIONS ARE PROPERTY OF SILVAN IND. INC. AND MAY NOT BE COPIED, REPRODUCED, OR USED IN WHOLE OR PART, AS A BASIS FOR DESIGN MANUFACTURE OR SALE WITHOUT PRIOR PERMISSION FROM SILVAN IND. INC.

REV	DESCRIPTION	BY	DATE
1	ISSUED		

UNLESS OTHERWISE SPECIFIED INCH TOLERANCES  
.X.....±.1  
.XX.....±.02  
.XXX.....±.005  
FRACTIONS.....±1/16  
ANGLE.....±1°  
FINISH.....250

THIRD ANGLE PROJ

TITLE  
**HORIZONTAL AIR RECEIVER**

CUSTOMER  
**CATALOG**

TYPE  
ASME

**SAMUEL**  
1865  
**PRESSURE VESSEL GROUP**

DRAWN <b>AET</b> 1/31/2025	CHECKED	DRAWING NO <b>237316</b> LEGACY PART NO 131-973	REV <b>1</b>
----------------------------------	---------	--	-----------------

SIZE: B SHEET 1 OF 1