

NOZZLE CHART		
NOZZLE ID	NPS SIZE	TYPE
N1	1/2	NPT
N2	1	NPT
N3	1 1/2	NPT
N4	2	NPT
N5	4	150# FLG
N6	MANWAY	

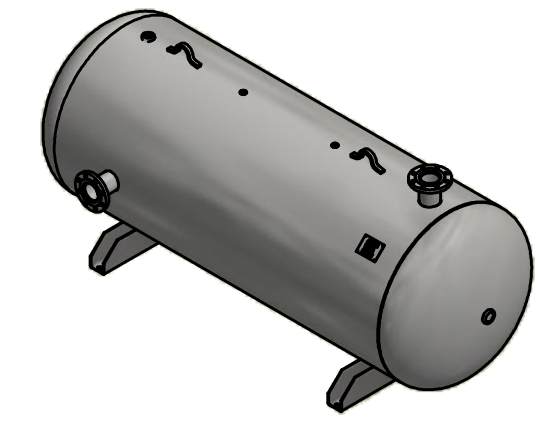
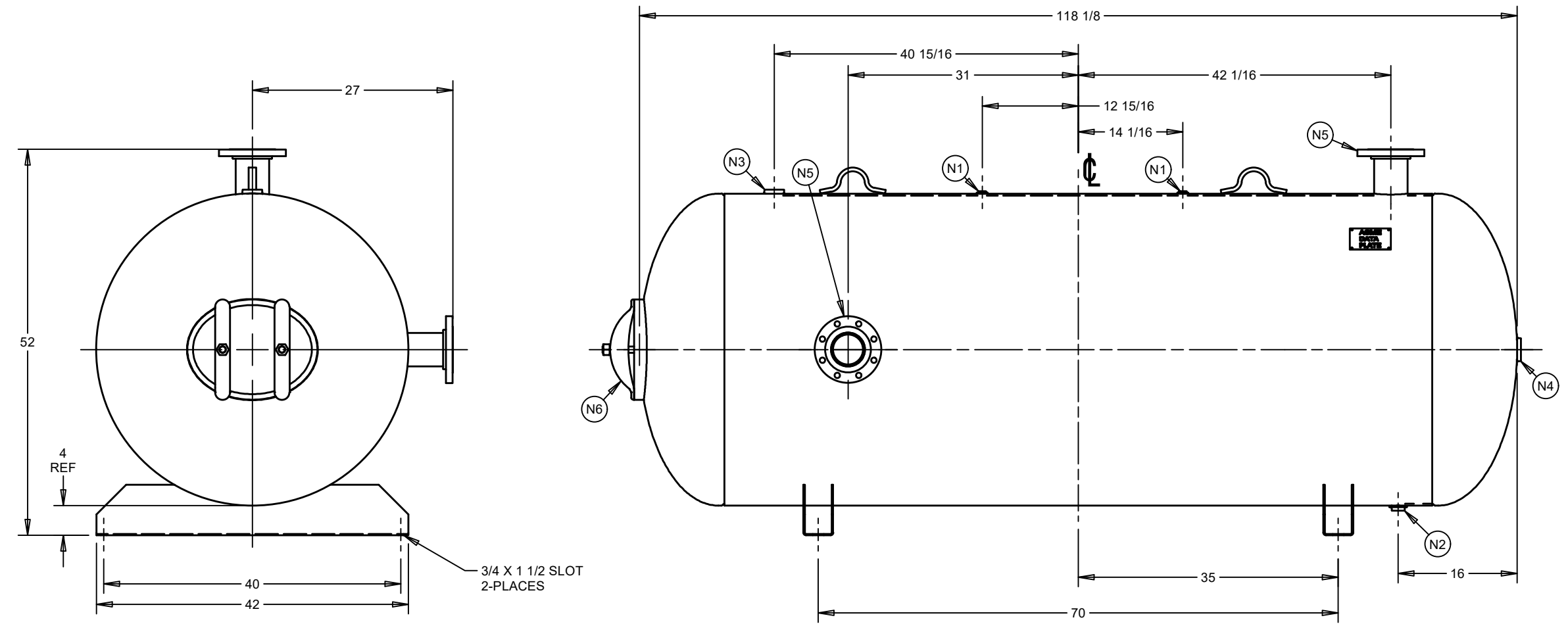

DESIGN INFORMATION	
SPECIFICATION	VALUE
DIAMETER O.D./I.D.	42 O.D.
MAWP	150 PSI AT 400°F
MDMT	-20°F AT 150 PSI
CAPACITY	APPROX 660 GALLONS
SHIPPING WEIGHT	1400 LBS
CRN	H9097.5C

TITLE HORIZONTAL AIR RECEIVER		DRAWN KAT		CHECKED DMM		DRAWING NO A10358		REV D14	
CUSTOMER STOCK		DATE 10/6/2016		DATE 10/17/2016		TYPE ASME		SIZE: B	
								SHEET 1 OF 1	

(BUILT IN ACCORDANCE WITH LATEST EDITION OF SECTION VIII DIV 1 ASME CODE)

THIS DRAWING & SPECIFICATIONS ARE PROPERTY OF SPVG AND MAY NOT BE COPIED, REPRODUCED, OR USED IN WHOLE OR PART, AS A BASIS FOR DESIGN MANUFACTURE OR SALE WITHOUT PRIOR PERMISSION FROM SPVG.

REV	DESCRIPTION	BY	DATE
D14	ISSUED		